

Type JAA circuit protection is designed for fuse function against excessive current around battery in portable electronic equipment because the demand for high capacity batteries is increasing. Since it is designed as chip type, it is compact and the best suitable for portable use. Also, the ecology design of Type JAA is gentle because of elimination of lead from terminals.

FEATURES

1. Low fusing point element that is newly developed is applied.
Has excellent fusing and cutting characteristics.
2. Surface temperature rise is 100°C or less when applying 200% rated current for fusing. This offers less influence on the peripheral units.
3. Size 3216 (3.2 × 1.6 mm), using resin mold and precision case
4. Suitable for automatic mounting
5. Precise dimensions allows high-density mounting and symmetrical construction of terminals provide "Self-Alignment".
6. Resistance to soldering heat : Reflow or flow soldering 10 seconds at 260°C
7. Standard package : 8 mm width tape carrier.
8. LEAD FREE and RoHS Compliant

RATING

Item	Rating
Category Temperature Range	-40 ~+125°C
Rated Current	0.5-0.63-0.8-1.0-1.25-1.6-2.0A
Rated Voltage	24VDC
Voltage Drop	Refer to CATALOG NUMBERS AND RATING
Insulation Resistance (between terminals and case)	1000 MΩ or more
Fusing Characteristics	Fusing within 2 minute if the current is 200% of rated current.
Clearing Characteristics	Breaking voltage : 24 V
	Breaking current : 50 A

ORDERING INFORMATION

JAA			2402		102		NA		010	
Type	Code	RV	Code	Rated current	Code	Rated current	Code	Package type	Special product code	
JAA	2402	24V	501	0.5 A	132	1.25A	NA	φ180'リール	010	
			631	0.63A	162	1.6 A				
			801	0.8 A	202	2.0 A				
			102	1.0 A						

CATALOG NUMBERS AND RATING

February, 2011

Catalog number	Case size mm	Rated current A	Internal resistance mΩ	Voltage drop mV (Max.)	Rated voltage VDC	Breaking current A
JAA 2402 501 □□010	3.2 × 1.6	0.5	154	100	24	50
JAA 2402 631 □□010	3.2 × 1.6	0.63	110	100		
JAA 2402 801 □□010	3.2 × 1.6	0.8	82	100		
JAA 2402 102 □□010	3.2 × 1.6	1.0	63	100		
JAA 2402 132 □□010	3.2 × 1.6	1.25	50	100		
JAA 2402 162 □□010	3.2 × 1.6	1.6	39	100		
JAA 2402 202 □□010	3.2 × 1.6	2.0	30	100		

For the taping type, the packing code "NA" will be entered in □□.

DIMENSIONS

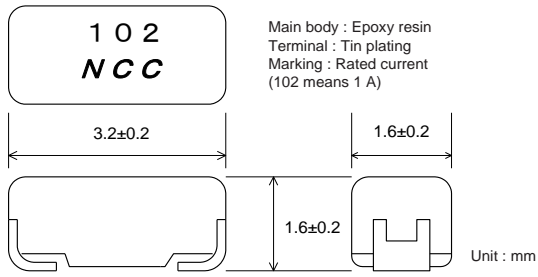

MARKING

Code	Rated current
501	0.50A
631	0.63A
801	0.80A
102	1.00A
132	1.25A
162	1.60A
202	2.00A

CONSTRUCTION

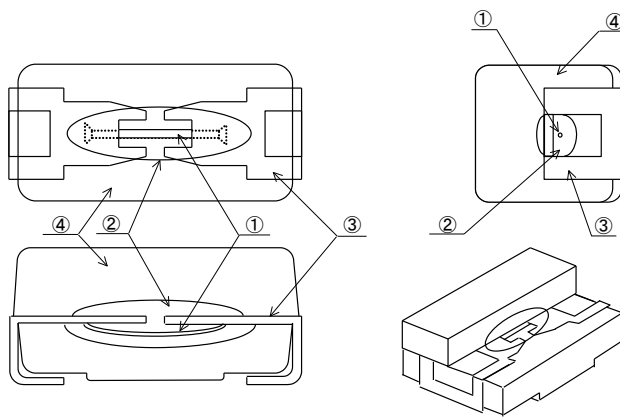

Number	Name	Material etc.
①	Fuse element	Lead alloy
②	Arc extinction material	Silicone resin
③	Terminal	Tin plating
④	Body	Epoxy resin

RECOMMENDED PAD DIMENSIONS

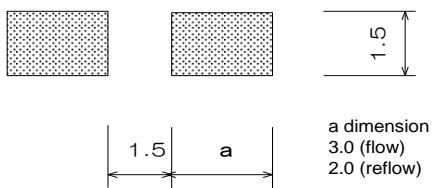

STANDARD TEST BODY

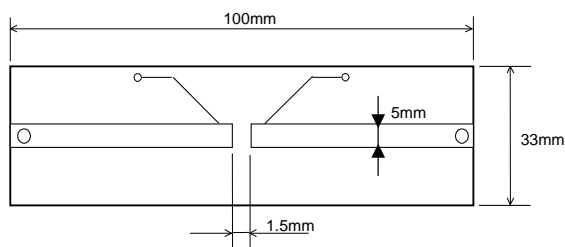

Glass epoxy body on one side
Board thickness : 1.6 mm
Copper layer : 35μm

PERFORMANCE

No.	Item	Performance	Test method
1	Temperature rise	Temperature rise shall not exceed 40°C.	Apply rated current. (Ambient temperature : 10 ~ 30°C)
2	Current-carrying capacity	Shall not open.	Apply 125% of rated current.
3	Clearing characteristics	Arc shall not be continued. Crack shall not initiate in peripheral case.	Breaking voltage : 24V Breaking current : 50 A
4	Voltage drop	Voltage drop is below the value specified in CATALOG NUMBERS AND RATING.	Apply rated current using 24 V power supply.
5	Fusing characteristics	Fusing within 2 min.	Apply 200% of rated current.
6	Insulation resistance	1000 MΩ or more	Insulation resistance between terminals and case
7	Electrode strength (Bending)	No mechanical damage. Shall meet the electric performance.	Board supporting width : 90 mm Bending speed : Approx. 0.5 mm/sec. Duration : 30 sec. Bending : 3 mm
8	Solderability (Solder Wetting time)	Solder Wetting time : within 3sec.	Solder : Sn-3Ag-0.5Cu Temperature : 245 ± 3°C meniscograph method Solder : JISZ3282 H60A, H60S, H63A Temperature : 230 ± 2°C meniscograph method
9	Solderability (new uniform coating of solder)	The dipping surface of the terminals shall be covered more than 95% with new solder.	Solder : Sn-3Ag-0.5Cu Temperature : 245 ± 3°C Dipping : 3 sec. Solder : JISZ3282 H60A, H60S, H63A Temperature : 230 ± 2°C Dipping : 3 sec.
10	Resistance to soldering heat	Marking shall be legible. No mechanical damage. Shall meet the electric performance.	Dipping Preconditioning : 100 ~ 150°C, 60 sec. Temperature : 260 ± 5°C, 10 ± 1 sec. Reflow soldering Preconditioning : 1 ~ 2 min, 180°C or less Peak : 250 ± 5°C, 5 sec. Holding : 230 ~ 250°C, 20 ~ 40 sec. Cooling : more than 2 min. Manual soldering Iron edge temperature : higher than 400°C Duration : 3 ~ 4 sec.
11	Thermal shock	No mechanical damage. Voltage drop after the test shall be less than the value specified in CATALOG NUMBERS AND RATING.	-55 ± 3°C : 30 min. Room temperature : 2 ~ 3 min or less 125 ± 2°C : 30 min. Room temperature : 2 ~ 3 min or less Repeat above step for 10 cycles
12	Moisture resistance	No mechanical damage. Voltage drop after the test shall be less than the value specified in CATALOG NUMBERS AND RATING.	Temperature : 85 ± 3°C Humidity : 85 ± 3% RH Duration : 1000 ⁺⁴⁸ hours
13	Moisture resistance load	No mechanical damage. Voltage drop after the test shall be less than the value specified in CATALOG NUMBERS AND RATING.	Temperature : 85 ± 3°C Humidity : 85 ± 3% RH Applied voltage : rated current × 125% Duration : 1000 ⁺⁴⁸ hours
14	Load life	No mechanical damage. Voltage drop after the test shall be less than the value specified in CATALOG NUMBERS AND RATING.	Temperature : 85 ± 3°C Applied current : Rated current × 125% Duration : 1000 ⁺⁴⁸ hours
15	Stability	No mechanical damage. Voltage drop after the test shall be less than the value specified in CATALOG NUMBERS AND RATING.	Temperature : 125 ± 3°C Duration : 1000 ⁺⁴⁸ hours

FUSING CHARACTERISTICS

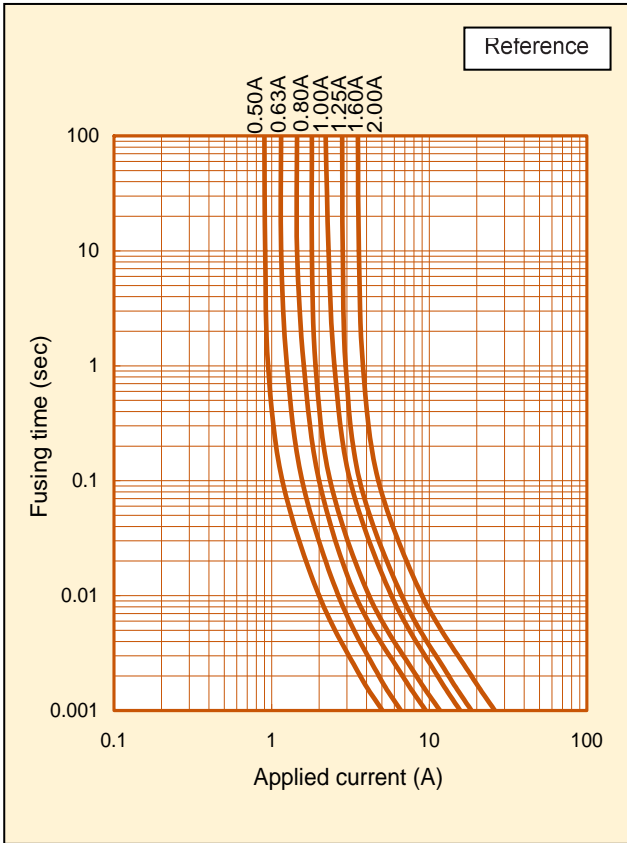

I²T CHARACTERISTICS

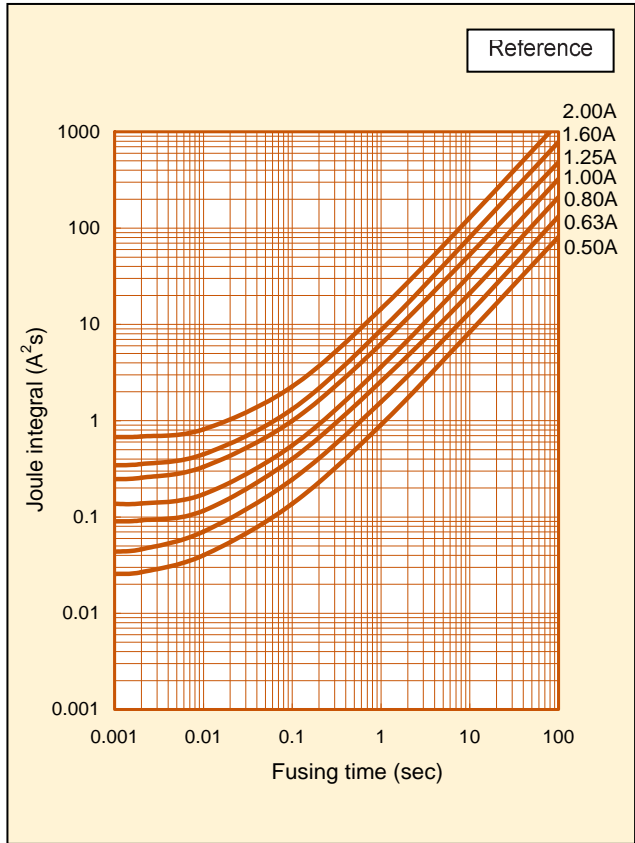

DISTRIBUTION OF FUSING CHARACTERISTICS

JAA 2402 102 n=1140

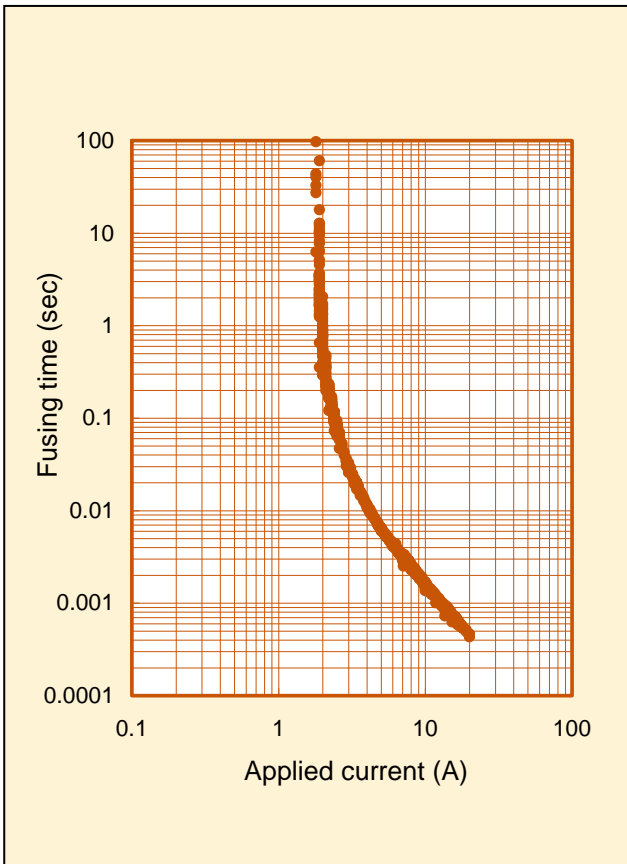

DISTRIBUTION OF FUSING TIME

JAA 2402 102 n=100

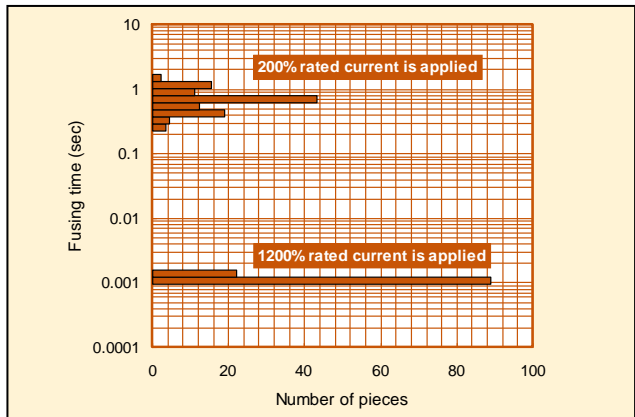

JAA 2402 501 n=100

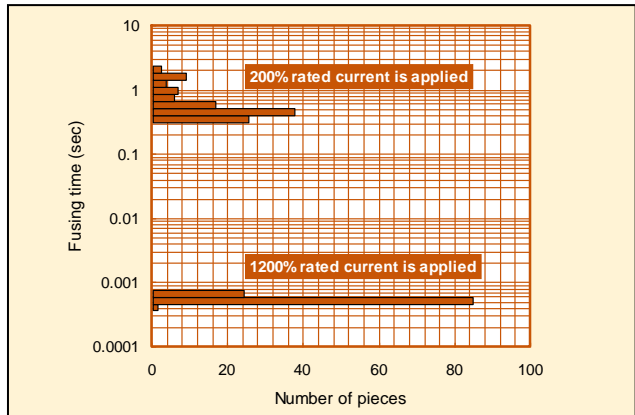

DETERMINATION OF RATED VALUE AND SELECTION OF CIRCUIT PROTECTION ELEMENT (TYPE JAA)

Determine the rated value of circuit protection element, and select the correct circuit protection element for your circuit. If you select the correct circuit protection element, safety of your circuit can be ensured.

How to determine the rated value of the circuit protection element is described below :

■ Flow for fuse selection

1. Measurement of circuit values using actual device

Measure the circuit values, such as operating current of the circuit.

2. Calculation from operating current

From the obtained operating current and the category temperature, calculate the minimum rated value to determine the applicable fuse.

3. Calculation from overload current

From the obtained overload current, calculate the maximum rated value to determine the applicable fuse.

4. Calculation from inrush current

From the inrush current, calculate the minimum rated value to determine the applicable fuse.

5. Final determination of rated value

From the calculation results of steps 2 through 4, determine the rated value.

6. Operation check using actual device

After selecting the rating, confirm if the device works properly under the pre-determined conditions.

■ Fuse selection

1. Measurement of circuit values using actual device

Before determining the rated value of the fuse, preliminarily measure the following using the actual device.

1-1 Operating current

Using an oscilloscope or equivalents, measure the operating current of the circuit.

1-2 Overload current

Using an oscilloscope or equivalents, measure the overload current that needs to break the circuit.

1-3 Inrush current

Using an oscilloscope or equivalents, measure the inrush current of the circuit at power-on or power-off. In addition, determine the number of inrush current applied.

1-4 Category temperature

Measure the ambient temperature of the fuse circuit.

EXAMPLE TO SELECT RATINGS OF TYPE JAA

<Fuse selection>

Effective operating current : 1.2 A

Effective overload current : 6.0 A

Inrush current waveform : Fig. A

(Pulse width : 1 ms, Wave height : 20A)

Numbers to withstand inrush current : 100,000 times

Category temperature : 85°C

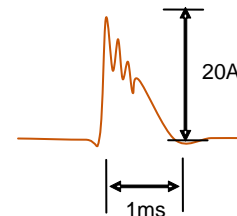

Fig. A : Inrush current waveform

2. Calculation from operating current

2-1 Measurement of operating current

Using an oscilloscope or equivalents, measure operating current (effective current) of the actual circuit.

Example : Effective operating current = 1.2 A

2-2 Derating

① Temperature derating factor

Using Fig. B, find the temperature derating factor correspond to the temperature.

② Rated derating factor

Rated derating factor = 1.0 (Constant irrespective of temperature)

Use Formula 1 to calculate the rated current of the fuse to be used for the circuit.

Rated current of fuse \geq Operating current / (① \times ②) ... Formula 1

Example: Category temperature = 85°C, Operating current = 1.2 A

① Temperature derating factor = 0.96 (Refer to Fig. B.)

② Rated derating factor = 1.0 (Constant irrespective of temperature)

Calculation using Formula 1 :

Rated current $\geq 1.2 / (0.96 \times 1.0) = 1.25$ A

The above calculation result shows that the fuse with rated current of 1.25 A or more should be selected for this circuit.

Type JAA, with rated current of 1.25 A or more can be selected.

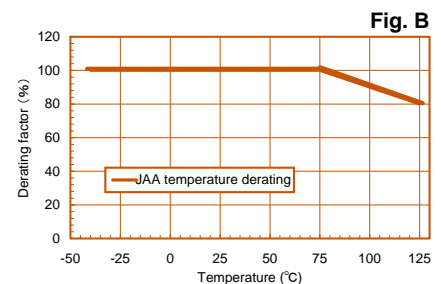

3. Calculation from overload current

3-1 Measurement of overload current

Using oscilloscope or equivalents, measure the overload current that needs to break the circuit.

Example : Effective overload current = 6.0 A

3-2 Calculation from overload current

Determine the rated current so that the overload current can be 2.0 times larger than the rated current.

Use Formula 2 to calculate the rated current of the fuse.

Rated current of fuse \leq Overload current / 2.0 ... Formula 2

Example : Overload current = 6.0 A

Use Formula 2 to calculate the rated current.

Rated current \leq 6.0 / 2.0 = 3.0 A

The above calculation result shows that the fuse with rated current of 3.0 A or less should be selected for this circuit.

Type JAA, with rated current of 2.0 A or less can be selected.

4. Calculation from inrush current

4-1 Measurement of inrush current waveform

Using an oscilloscope or equivalent, measure the waveform of the inrush current of the actual circuit.

4-2 Creation of approximate waveform

Generally, the waveform of inrush current is complicated. For this reason, create the approximate waveform of inrush current as shown on Fig. C to simplify calculation.

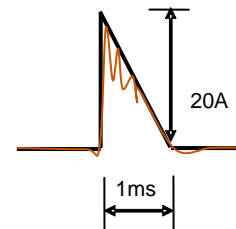

Fig. C : Inrush current waveform
Red line : Actual measurement waveform
Black line : Approximate waveform

4-3 Calculation of I²t of inrush current

Calculate I²t (Joule integral) of the approximate waveform.

The formula for this calculation depends on the approximate waveform.

Refer to Table A.

Example : Pulse applied = 1 ms, Peak value = 20 A,

Approximate waveform = Triangular wave

Since the approximate waveform is a triangular wave, use the following formula for calculation.

I²t of rush current = 1 / 3 × Im² × t ... Formula 3

(Im : Peak value, t : Pulse applying time)

Use Formula 3 to calculate I²t of the rush current :

I²t = 1 / 3 × 20 × 20 × 0.001 = 0.13 (A²s)

JOULE-INTEGRAL VALUES FOR EACH WAVEFORM

Table A

Name	Waveform	I ² t	Name	Waveform	I ² t
Sine wave (1 cycle)		$\frac{1}{2} I_m^2 t$	Trapezoidal wave		$\frac{1}{3} I_m^2 t_1 + I_m^2 (t_2 - t_1) + \frac{1}{3} I_m^2 (t_3 - t_2)$
Sine wave (half cycle)		$\frac{1}{2} I_m^2 t$	Various wave 1		$I_1 I_2 t + \frac{1}{3} (I_1 - I_2)^2 t$
Triangular wave		$\frac{1}{3} I_m^2 t$	Various wave 2		$\frac{1}{3} I_1^2 t_1 + \{I_1 I_2 + \frac{1}{3} (I_1 - I_2)^2\} (t_2 - t_1) + \frac{1}{3} I_2^2 (t_3 - t_2)$
Rectangular wave		$I_m^2 t$	Charge/discharge waveform		$\frac{1}{2} I_m^2 t$

* Following formula is generally used for calculation of I²t as i(t) equal to current.

$$I^2t = \int_0^t i^2(t) dt$$

4-4 Search of load ratio

- ① Set up the number of cycles to withstand. (generally 100,000 times)
- ② Obtain the load ratio from Pulse resistance characteristics. (Fig. D)

Example : 100,000 times is required against inrush current applied.

The load ratio is 20% or less from Fig. D.

PULSE RESISTANCE CHARACTERISTICS

Fig. D

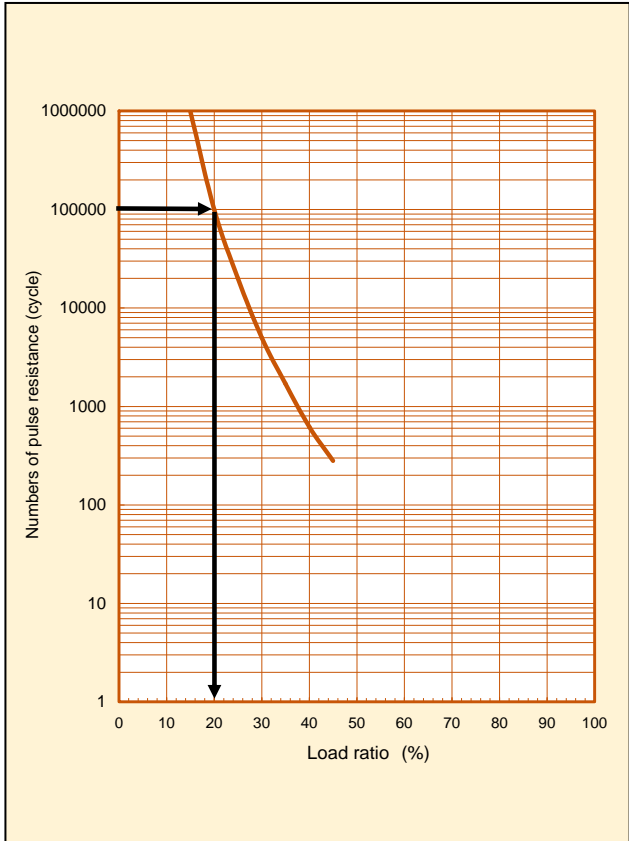

4-5 Calculation from Joule integral and load ratio

Use Formula 4 to calculate the standard I^2t for the fuse to be used.

Standard I^2t of fuse > (I^2t of inrush current / load ratio)
Formula 4

Example : I^2t of pulse = 0.13 A^2s , Pulse applied = 1 ms,
 Required load ratio = 20%

From Formula 4,
 Standard I^2t of fuse > 0.13 / 0.2 = 0.65 (A^2s)
 The standard I^2t of the fuse should be 0.65 (A^2s) or more.

Since the rush pulse applied is 1 ms, obtain the intersection of 1 ms (horizontal axis) and 0.65 A^2s (vertical axis) from Fig. E (refer to the arrow shown in Fig.E).

Select a fuse whose curve is above the intersection. Type JAA, with rated current of 2.0 A or more should be selected.

5. Final determination of rated value

Determine the rated current of the circuit protection element. The rated current should meet all the calculation results.

Example : 2.0 A meet the all requirement.

6. Operation check using actual device

After selecting the rating, confirm if the device works properly under the pre-determined conditions.

JOULE INTEGRAL VS. FUSING TIME

Fig. E

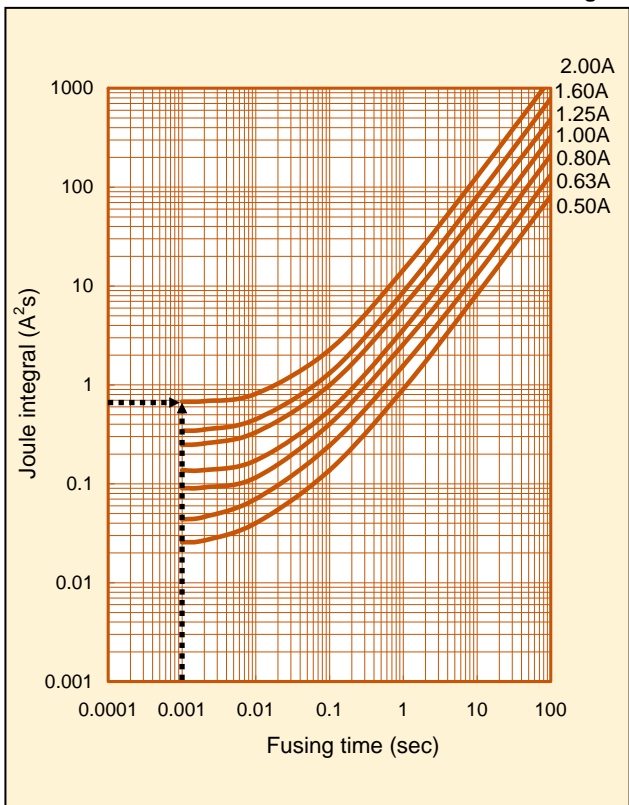



Application Notes for Circuit Protector

1. Circuit Design

Circuit Protector should be designated only after confirming operating conditions and the Circuit Protector performance characteristics.

When determining the rated current, be sure to observe the following items :

- (1) Circuit Protector should always be operated below the rated current (the value considered in the temperature derating rate) and voltage specifications. According to item 2.2-2 in page 5.
- (2) Circuit Protector should always be operated below the rated voltage.
- (3) Circuit Protector should be selected with correct rated value to be fused at overload current.
- (4) When Circuit Protector are used in inrush current applications, please confirm sufficiently inrush resistance of Circuit Protector.
- (5) Please do not apply the current exceeding the breaking current to Circuit Protector.
- (6) Use Circuit Protector under the condition of category temperature.
- (7) Circuit Protector should not be used in the primary power source.

Circuit Protector should be selected by determining the operating conditions that will occur after final assembly, or estimating potential abnormalities through cycle testing.

2. Assembly and Mounting

During the entire assembly process, observe Circuit Protector body temperature and the heating time specified in the performance table. In addition, observe the following items :

- (1) Mounting and adjusting with soldering irons are not recommendable since temperature and time control is difficult.
In case of emergency for using soldering irons, be sure to observe the conditions specified in the performance table.
- (2) Circuit Protector body should not have direct contact with a soldering iron.
- (3) Once Circuit Protector mounted on the board, they should never be remounted on boards or substrates.
- (4) During mounting, be careful not to apply any excessive mechanical stresses to the Circuit Protector.

3. Solvents

For cleaning of Circuit Protector, immersion in isopropyl alcohol for 90 seconds (at 20 ~ 30°C liquid temp.) will not be damaged. If organic solvents (Pine Alpha™, Techno Care™, Clean Through™, etc.) will be applied to the Circuit Protector, be sure to preliminarily check that the solvent will not damage the Circuit Protector.

4. Ultrasonic Cleaning

Ultrasonic cleaning is not recommended for Circuit Protector. This may cause damage to the Circuit Protector such as broken terminals which results in electrical characteristics effects, etc. depending on the conditions.

If Ultrasonic cleaning process must be used, please evaluate the effects sufficiently before use.

5. Caution During Usage

- (1) Circuit Protector with electricity should never be touched. Circuit Protector with electricity may cause burning due to the Circuit Protector high temperature. Also, in case of touching Circuit Protector without electricity, please check the safety temperature of Circuit Protector.
- (2) Protective eyeglasses should always be worn when performing fusing tests. However, there is a fear that Circuit Protector will explode during test. During fusing tests, please cover particles not to fly outward from the board or testing fixture. Caution is necessary during usage at all times.

6. Environmental Conditions

- (1) Circuit Protector should not be operated in acid or alkali corrosive atmosphere.
- (2) Circuit Protector should not be vibrated, shocked, or pressed excessively.
- (3) Circuit Protector should not be operated in a flammable or explosive atmosphere.
- (4) After mounting Circuit Protector on a board, covering Fuses with resin may affect to the electric characteristics of the Circuit Protector. Please be sure to evaluate it in advance.

7. Emergency

In case of fire, smoking, or offensive odor during operation, please cut off the power in the circuit or pull the plug out.

8. Storage

- (1) Circuit Protector should be stored at room temperature (-10°C ~ +40°C) without direct sunlight but not in corrosive atmosphere such as H₂S (hydrogen sulfide) or SO₂ (sulfur dioxide). Direct sunlight may cause decolorization and deformation of the exterior and taping. Also, there is a fear that solderability will be remarkably lower in high humidity.
- (2) If the products are stored for an extended period of time, please contact Matsuo Sales Department for recommendation. The longer storage term causes packages and tapings to worsen. If the products are stored for longer term, please contact Matsuo Sales Department for advice.
- (3) The products in taping, package, or box should not be given any kind of physical pressure. Deformation of taping or package may affect automatic mounting.

9. Disposal

When Circuit Protector are disposed of as waste or "scrap", they should be treated as "industrial waste". Circuit Protector contain various kinds of metals and resins.

10. Samples

Circuit Protector received as samples should not be used in any products or devices in the market. Samples are provided for a particular purpose such as configuration, confirmation of electrical characteristics, etc.



MATSUO ELECTRIC CO., LTD.

Please feel free to ask our sales department for more information on the Circuit Protector.

Overseas Sales Dep. 5-3,3-Chome,Sennari-cho,Toyonaka-shi,Osaka 561-8558,Japan Tel : 06-6332-0883 Fax : 06-6332-0920
Head office 5-3,3-Chome,Sennari-cho,Toyonaka-shi,Osaka 561-8558,Japan Tel : 06-6332-0871 Fax : 06-6331-1386
URL <http://www.ncc-matsuo.co.jp/>

Specifications on this catalog are subject to change without prior notice. Please inquire of our Sales Department to confirm specifications prior to use.